

SWITCH DEBOUNCE AND SYNCHRONIZATION
THE COMPLETE SOLUTION TO THIS PROBLEM IS BELOW

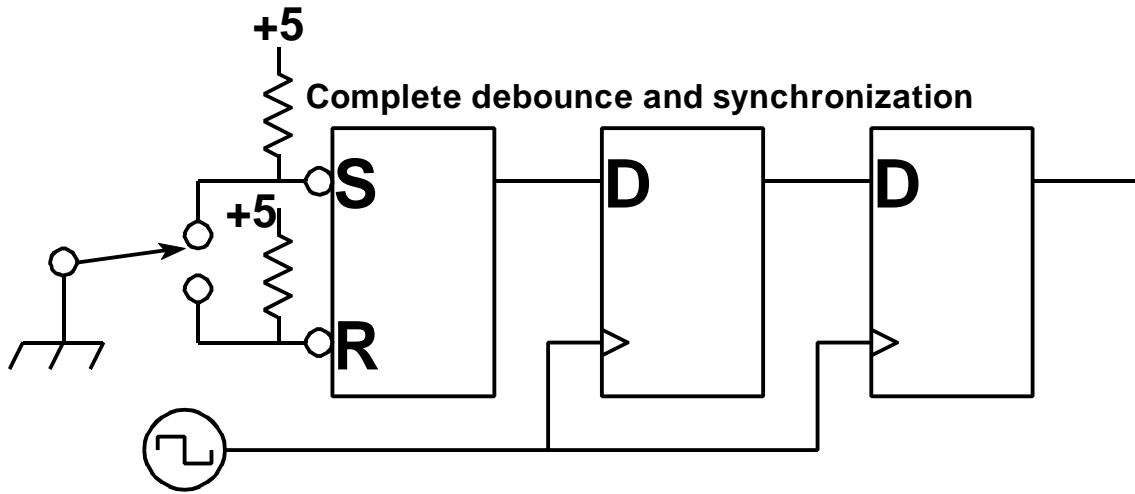

The SR Latch debounces the switch, the first D flip-flop synchronizes it, and the second D flip-flop eliminated metastability problems. Partial solutions are possible when one of these three features is not needed. The debouncing and synchronization may be done in a PLD and only the external pull-up resistors required.

The StateCAD representation of this solution is shown to the right. With the button released, SW_NC (Normally Closed) is grounded - SW_NC= 0. When the switch or button is activated, SW_NC goes high (with, perhaps a bounce or two. Bouncing occurs mostly when the contacts close). Finally SW_NO (Normally Open) goes to 0 (and bounces), indicating the switch (button) is on. Turning the switch off (releasing the button) reverses the process.

The equations generated by StateCAD and WARP are shown below.

DESIGN EQUATIONS (08:40:06)

$$\begin{aligned} \text{switch.D} &= \text{/sw_no} * \text{/switch.Q} \\ &\quad + \text{sw_nc} * \text{switch.Q} \\ \text{switch.C} &= \text{clk} \end{aligned}$$

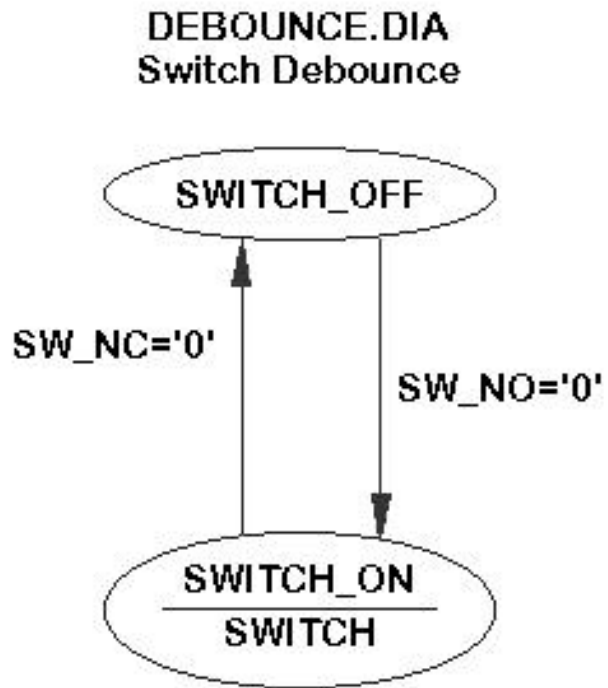

A Simulation of this is shown below.

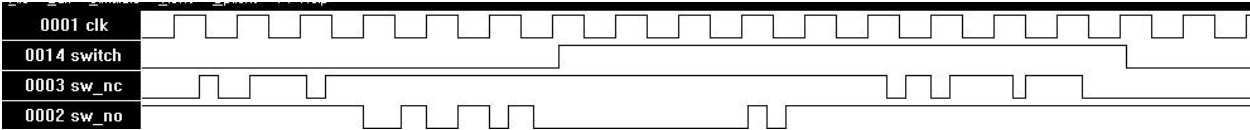

The above solution combines the action of the SR latch and the first D flip-flop. If these are separated, somewhat faster operation is obtained. This has to be done by hand since StateCAD does synchronous design. It amounts to implementing an SR latch in VHDL (Homework assignment 2) followed by the D flip-flop.

The simulation obtained this way is below.

