

SN55114, SN75114 DUAL DIFFERENTIAL LINE DRIVERS

SLLS071B – SEPTEMBER 1973 – REVISED MAY 1995

- Choice of Open-Collector, Open-Emitter, or Totem-Pole Outputs
- Single-Ended or Differential AND/NAND Outputs
- Single 5-V Supply
- Dual-Channel Operation
- TTL Compatible
- Short-Circuit Protection
- High-Current Outputs
- Triple inputs
- Clamp Diodes at Inputs and Outputs
- Designed for Use With SN55115 and SN75115 Differential Line Receivers
- Designed to Be Interchangeable With National DS9614 Line Driver

description

The SN55114 and SN75114 dual differential line drivers are designed to provide differential output signals with the high-current capability for driving balanced lines, such as twisted pair, at normal line impedances without high power dissipation. The output stages are similar to TTL totem-pole outputs, but with the sink outputs, YS and ZS, and the corresponding active pullup terminals, YP and ZP, available on adjacent package pins. Since the output stages provide TTL-compatible output levels, these devices may also be used as TTL expanders or phase splitters.

The SN55114 is characterized for operation over the full military temperature range of -55°C to 125°C . The SN75114 is characterized for operation from 0°C to 70°C .

SN55114 . . . J OR W PACKAGE
SN75114 . . . D OR N PACKAGE

(TOP VIEW)

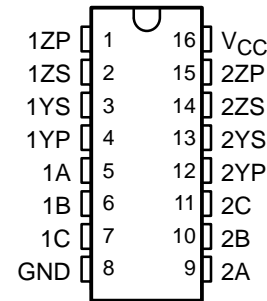

SN55114 . . . FK PACKAGE

(TOP VIEW)

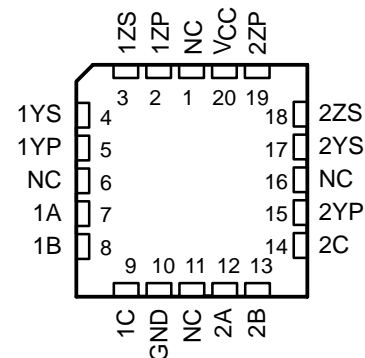

NC – No internal connection

FUNCTION TABLE

INPUTS			OUTPUTS	
A	B	C	Y	Z
H	L	H	H	L
All other inputs combinations			L	H

H = high level, L = low level

SN55114, SN75114 DUAL DIFFERENTIAL LINE DRIVERS

SLLS071B – SEPTEMBER 1973 – REVISED MAY 1995

logic symbol†

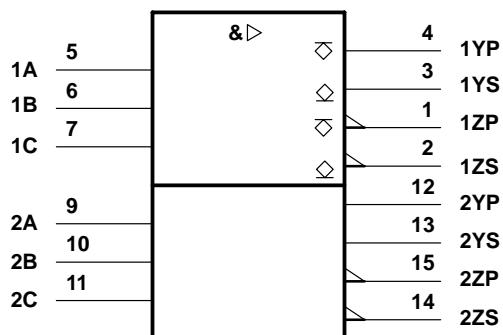

logic diagram (positive logic)

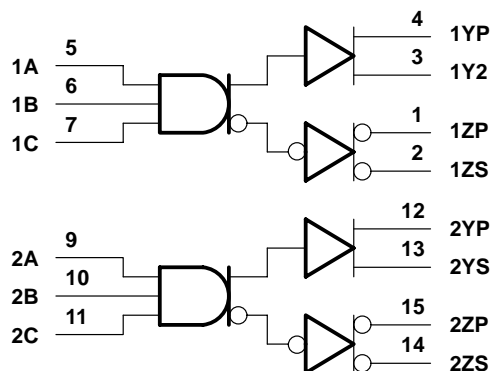

† This symbol is in accordance with ANSI/IEEE Std 91-1984 and IEC Publication 617-12.

Pin numbers shown are for the D, J, N, and W packages.

schematic (each driver)

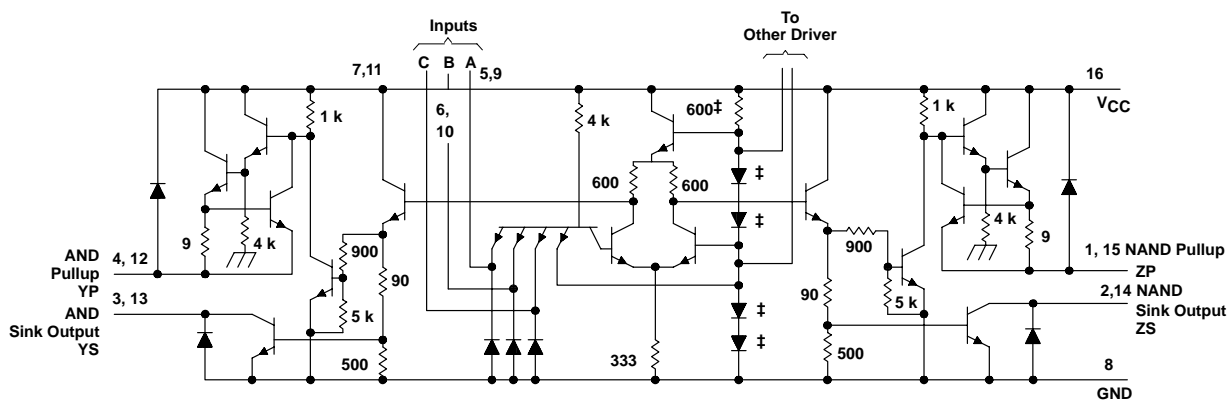

‡ These components are common to both drivers. Resistor values shown are nominal and in ohms.

Pin numbers shown are for the D, J, N, and W packages.

SN55114, SN75114 DUAL DIFFERENTIAL LINE DRIVERS

SLLS071B – SEPTEMBER 1973 – REVISED MAY 1995

absolute maximum ratings over operating free-air temperature range (unless otherwise noted)[†]

	SN55114	SN75114	UNIT
Supply voltage, V_{CC} (see Note 1)	7	7	V
Input voltage, V_I	5.5	5.5	V
Off-state voltage applied to open-collector outputs	12	12	V
Continuous total power dissipation	See Dissipation Rating Table		
Operating free-air temperature range, T_A	-55 to 125	0 to 70	°C
Storage temperature range, T_{stg}	-65 to 150	-65 to 150	°C
Case temperature for 60 seconds, T_C : FK package	260		°C
Lead temperature 1,6 mm (1/16 inch) from case for 60 seconds: J or W package	300		°C
Lead temperature 1,6 mm (1/16 inch) from case for 10 seconds: D or N package		260	°C

[†] Stresses beyond those listed under “absolute maximum ratings” may cause permanent damage to the device. These are stress ratings only, and functional operation of the device at these or any other conditions beyond those indicated under “recommended operating conditions” is not implied. Exposure to absolute-maximum-rated conditions for extended periods may affect device reliability.

NOTE 1: Voltage values are with respect to network ground terminal.

DISSIPATION RATING TABLE

PACKAGE	$T_A \leq 25^\circ\text{C}$ POWER RATING	DERATING FACTOR ABOVE $T_A = 25^\circ\text{C}$	$T_A = 70^\circ\text{C}$ POWER RATING	$T_A = 125^\circ\text{C}$ POWER RATING
D	950 mW	7.6 mW/°C	608 mW	—
FK [‡]	1375 mW	11.0 mW/°C	880 mW	275 mW
J [‡]	1375 mW	11.0 mW/°C	880 mW	275 mW
N	1150 mW	9.2 mW/°C	736 mW	—
W [‡]	1000 mW	8.0 mW/°C	640 mW	200 mW

[‡] In the FK, J, and W packages, SN55114 chips are either silver glass or alloy mounted.

recommended operating conditions

	SN55114			SN75114			UNIT
	MIN	NOM	MAX	MIN	NOM	MAX	
Supply voltage, V_{CC}	4.5	5	5.5	4.75	5	5.25	V
High-level input voltage, V_{IH}	2			2			V
Low-level input voltage, V_{IL}	0.8			0.8			V
High-level output current, I_{OH}	-40			-40			mA
Low-level output current, I_{OL}	40			40			mA
Operating free-air temperature, T_A	-55		125	0		70	°C

SN55114, SN75114 DUAL DIFFERENTIAL LINE DRIVERS

SLLS071B – SEPTEMBER 1973 – REVISED MAY 1995

electrical characteristics over recommended operating free-air temperature range (unless otherwise noted)

PARAMETER	TEST CONDITION [†]	SN55114			SN75114			UNIT			
		MIN	TYP [‡]	MAX	MIN	TYP [‡]	MAX				
V _{IK}	Input clamp voltage	V _{CC} = MIN, I _I = -12 mA			-0.9	-1.5	-0.9	-1.5	V		
V _{OH}	High-level output voltage	V _{CC} = MIN, V _{IH} = 2 V, V _{IL} = 0.8 V		I _{OH} = -10 mA		2.4	3.4	2.4	3.4	V	
				I _{OH} = -40 mA		2	3	2	3		
V _{OL}	Low-level output voltage	V _{CC} = MIN, V _{IH} = 2 V, V _{IL} = 0.8 V, I _{OL} = 40 mA			0.2	0.4	0.2	0.45	V		
V _{OK}	Output clamp voltage	V _{CC} = 5 V, I _O = 40 mA, T _A = 25°C			6.1	6.5	6.1	6.5	V		
		V _{CC} = MAX, I _O = -40 mA, T _A = 25°C			-1.1	-1.5	-1.1	-1.5			
I _{O(off)}	Off-state open collector output current	V _{CC} = MAX	V _{OH} = 12 V	T _A = 25°C		1	100		μA		
				T _A = 125°C		200					
			V _{OH} = 5.25 V	T _A = 25°C			1	100			
				T _A = 70°C			200				
I _I	Input current at maximum input voltage	V _{CC} = MAX, V _I = 5.5 V				1	1	mA			
I _{IH}	High-level input current	V _{CC} = MAX, V _I = 2.4 V				40	40	μA			
I _{IL}	Low-level input current	V _{CC} = MAX, V _I = 0.4 V			-1.1	-1.6	-1.1	-1.6	mA		
I _{OS}	Short-circuit output current [§]	V _{CC} = MAX, V _O = 0, T _A = 25°C			-40	-90	-120	-40	-90	-120	mA
I _{CC}	Supply current (both drivers)	All inputs at 0 V, No load, T _A = 25°C		V _{CC} = MAX		37	50	37	50	mA	
				V _{CC} = 7 V		47	65	47	70		

[†] All parameters with the exception of off-state open-collector output current are measured with the active pullup connected to the sink output. For conditions shown as MIN or MAX, use the appropriate value specified under recommended operating conditions.

[‡] All typical values are at T_A = 25°C and V_{CC} = 5 V, with the exception of I_{CC} at 7 V.

[§] Only one output should be shorted at a time, and duration of the short circuit should not exceed one second.

switching characteristics, V_{CC} = 5 V, T_A = 25°C

PARAMETER	TEST CONDITIONS	SN55114			SN75114			UNIT
		MIN	TYP	MAX	MIN	TYP	MAX	
t _{PLH}	Propagation delay time, low- to high-level output	C _L = 30 pF, See Figure 1		15	20	15	30	ns
t _{PHL}	Propagation delay time, high- to low-level output	11	20	11	30	ns		



PARAMETER MEASUREMENT INFORMATION

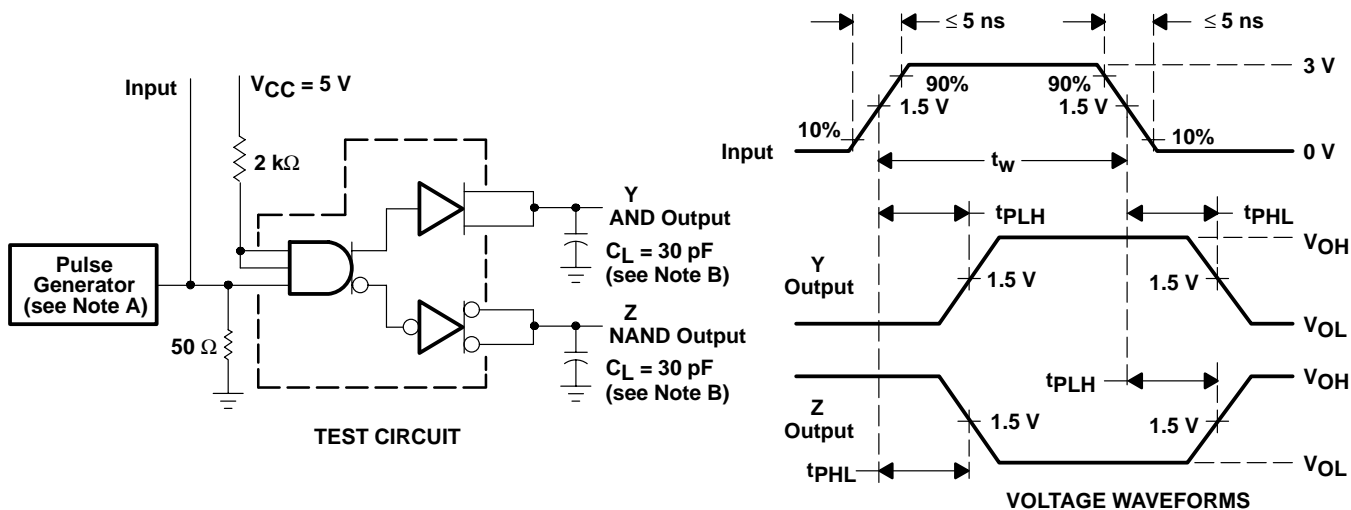

NOTES: A. The pulse generator has the following characteristics: $Z_O = 500 \Omega$, $PRR \leq 500 \text{ kHz}$, $t_w \leq 100 \text{ ns}$.
 B. C_L includes probe and jig capacitance.

Figure 1. Test Circuit and Voltage Waveforms

TYPICAL CHARACTERISTICS†

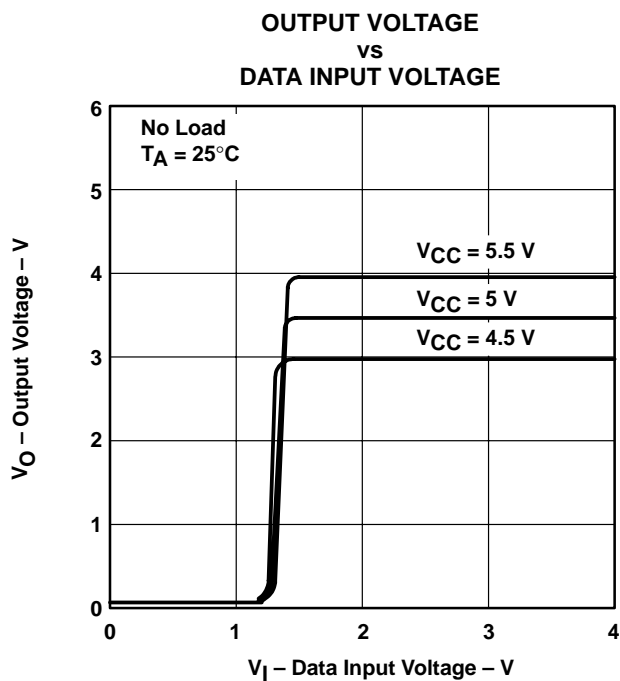

Figure 2

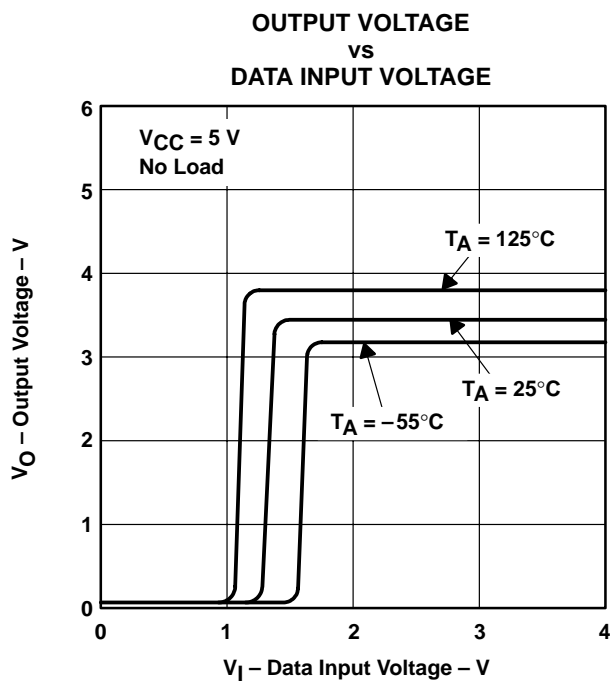

Figure 3

† Data for temperatures below 0°C and above 70°C and for supply voltages below 4.75 V and above 5.25 V are applicable to SN55114 circuits only. These parameters were measured with the active pullup connected to the sink output.

SN55114, SN75114 DUAL DIFFERENTIAL LINE DRIVERS

SLLS071B – SEPTEMBER 1973 – REVISED MAY 1995

TYPICAL CHARACTERISTICS†

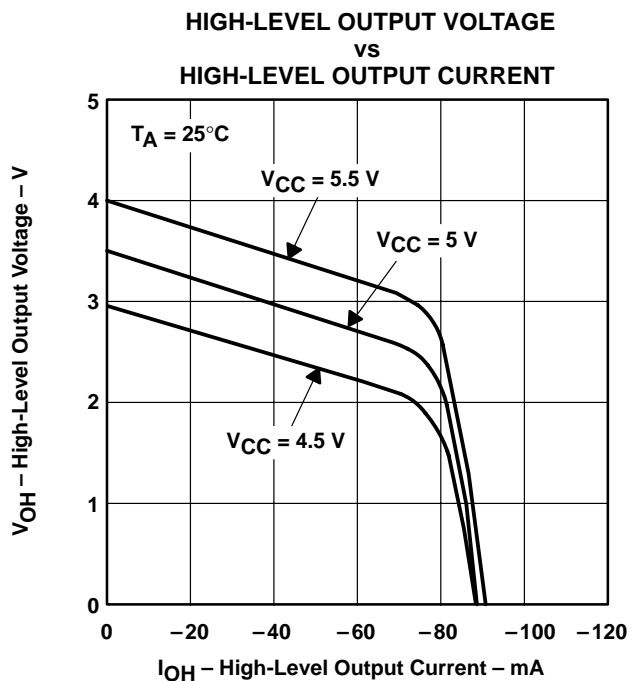

Figure 4

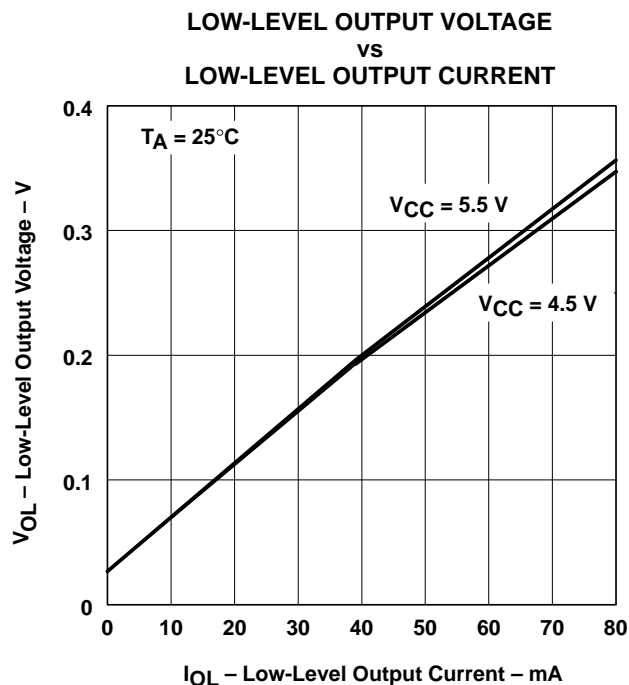

Figure 5

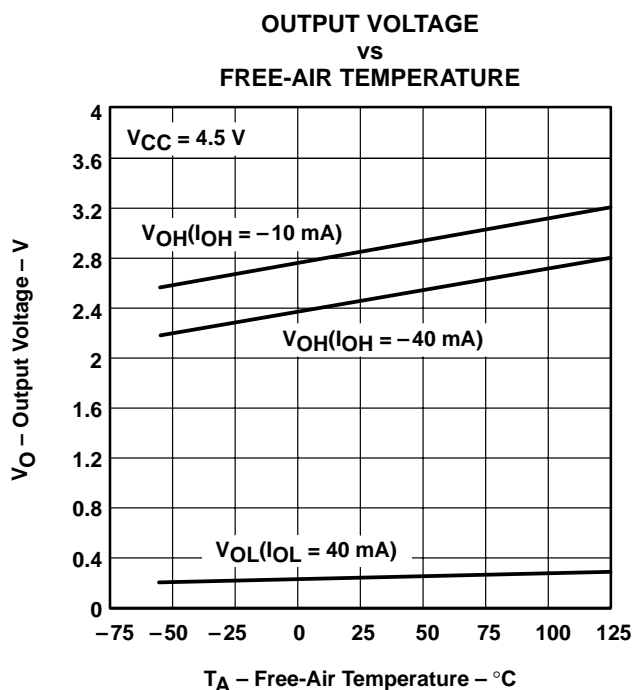

Figure 6

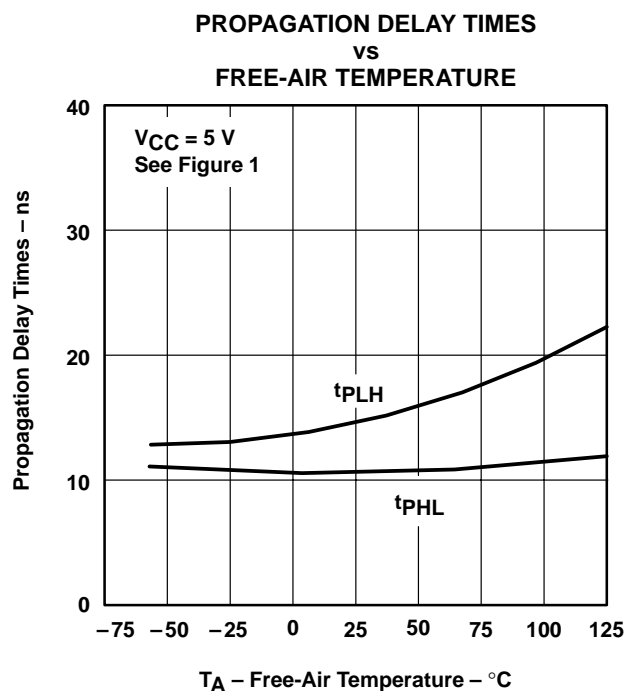

Figure 7

† Data for temperatures below 0°C and above 70°C are applicable to SN55114 circuits only. These parameters were measured with the active pullup connected to the sink output.

TYPICAL CHARACTERISTICS†

SUPPLY CURRENT
 (BOTH DRIVERS)
 vs
 SUPPLY VOLTAGE

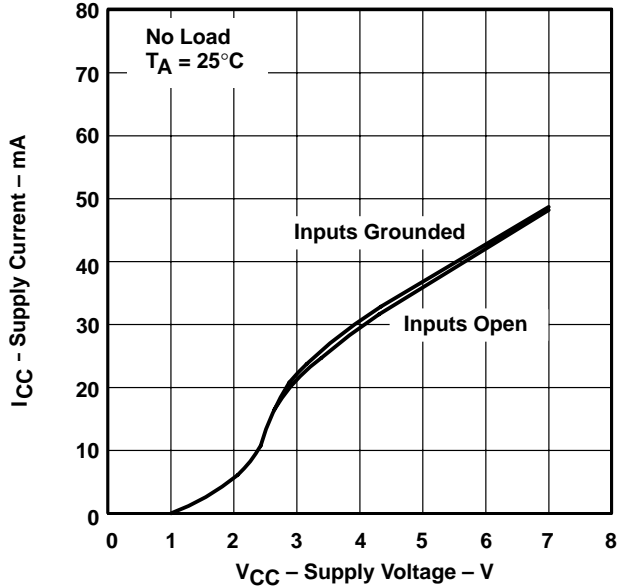

Figure 8

SUPPLY CURRENT
 (BOTH DRIVERS)
 vs
 FREE-AIR TEMPERATURE

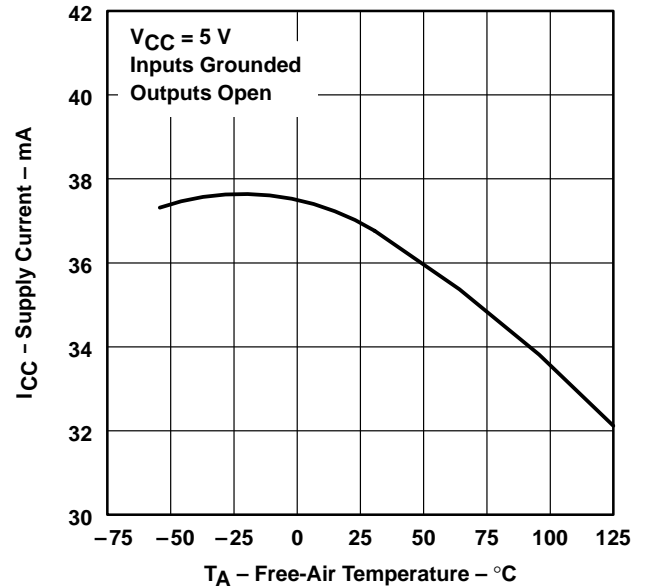

Figure 9

SUPPLY CURRENT
 (BOTH DRIVERS)
 vs
 FREQUENCY

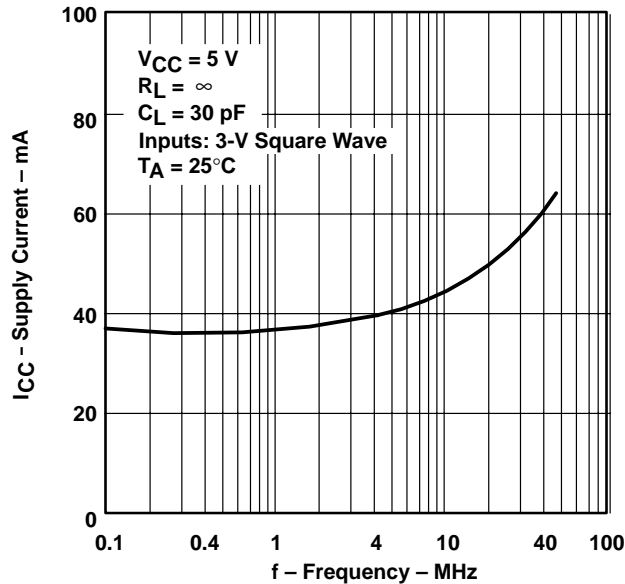

Figure 10

† Data for temperatures below 0°C and above 70°C are applicable to SN55114 circuits only. These parameters were measured with the active pullup connected to the sink output.

SN55114, SN75114 DUAL DIFFERENTIAL LINE DRIVERS

SLLS071B – SEPTEMBER 1973 – REVISED MAY 1995

APPLICATION INFORMATION



$^\dagger R_T = Z_0$. A capacitor may be connected in series with R_T to reduce power dissipation.

Figure 11. Basic Party-Line or Data-Bus Differential Data Transmission

IMPORTANT NOTICE

Texas Instruments (TI) reserves the right to make changes to its products or to discontinue any semiconductor product or service without notice, and advises its customers to obtain the latest version of relevant information to verify, before placing orders, that the information being relied on is current.

TI warrants performance of its semiconductor products and related software to the specifications applicable at the time of sale in accordance with TI's standard warranty. Testing and other quality control techniques are utilized to the extent TI deems necessary to support this warranty. Specific testing of all parameters of each device is not necessarily performed, except those mandated by government requirements.

Certain applications using semiconductor products may involve potential risks of death, personal injury, or severe property or environmental damage ("Critical Applications").

TI SEMICONDUCTOR PRODUCTS ARE NOT DESIGNED, INTENDED, AUTHORIZED, OR WARRANTED TO BE SUITABLE FOR USE IN LIFE-SUPPORT APPLICATIONS, DEVICES OR SYSTEMS OR OTHER CRITICAL APPLICATIONS.

Inclusion of TI products in such applications is understood to be fully at the risk of the customer. Use of TI products in such applications requires the written approval of an appropriate TI officer. Questions concerning potential risk applications should be directed to TI through a local SC sales office.

In order to minimize risks associated with the customer's applications, adequate design and operating safeguards should be provided by the customer to minimize inherent or procedural hazards.

TI assumes no liability for applications assistance, customer product design, software performance, or infringement of patents or services described herein. Nor does TI warrant or represent that any license, either express or implied, is granted under any patent right, copyright, mask work right, or other intellectual property right of TI covering or relating to any combination, machine, or process in which such semiconductor products or services might be or are used.